

SALES DRAWING SALES DRAWING SALES DRAWING SALES DRAWING SALES DRAWING

SALES DRAWING SALES DRAWING SALES DRAWING SALES DRAWING SALES DRAWING

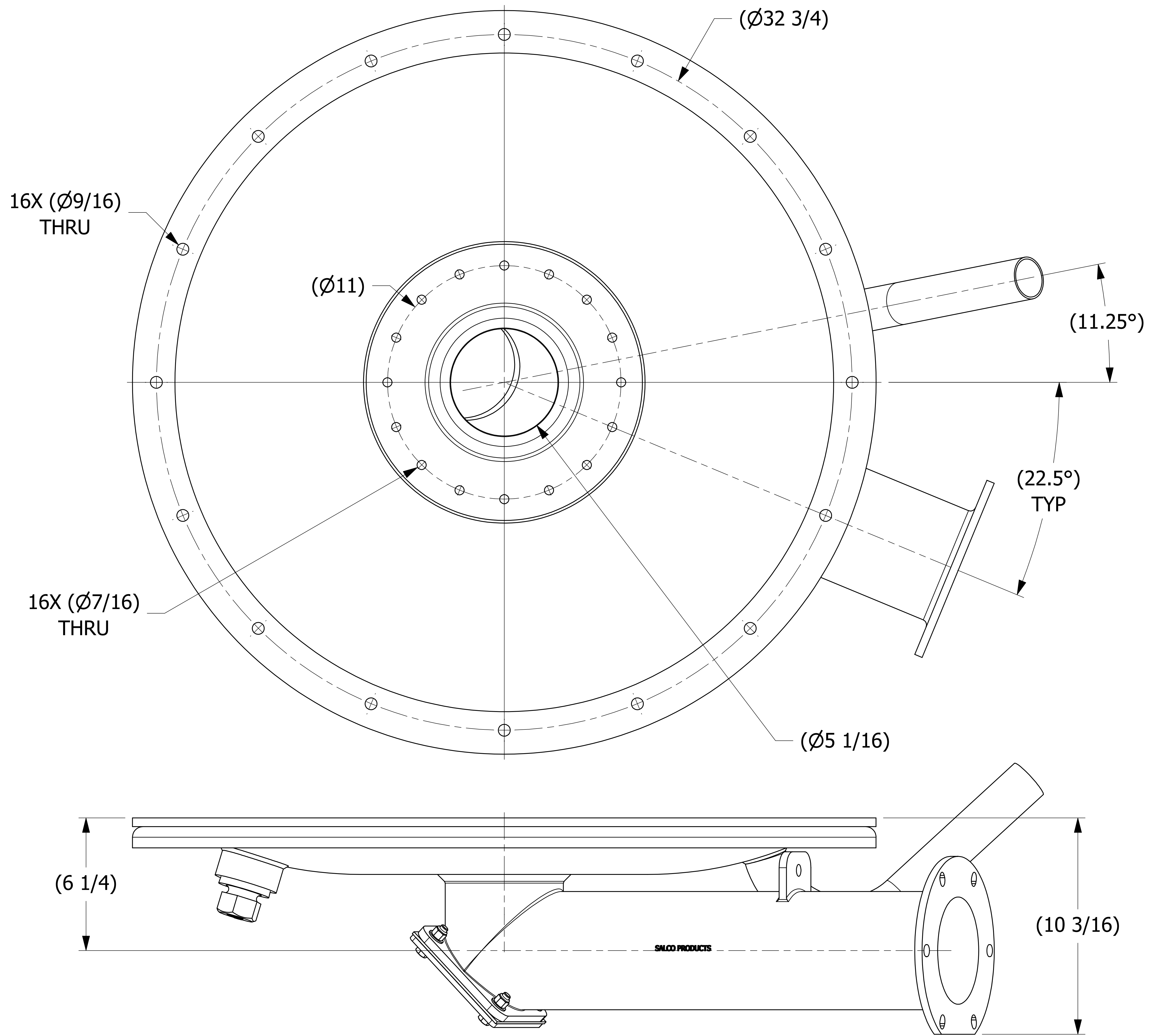

| | | | |
|-----|-----|----------|---|
| G | TAK | 10-11-17 | UPDATED DRAWING NUMBER, ADDED NOTE 4, DIM 22.5° WAS 23° |
| F | JJK | 8-14-14 | REMOVED TCP2 FROM THE BOM |
| E | CHL | 8-29-08 | REPLACED PD5ADT01, PD545ACP W/PD5ACDT01, PD545ACP2 |
| D | BRG | 2-22-08 | UPDATED TC2P TO CS/DI |
| C | CHL | 8-23-07 | ADDED NOTE 4 |
| B | ACC | 7-28-03 | LINING WAS POLYCLUTCH |
| A | ACC | 2-15-02 | UPDATED NOTES, PLATE ASS'Y WAS PD5ACPA |
| REV | BY | DATE | DESCRIPTION |

| | |
|--|---------------------------------|
| UNLESS OTHERWISE SPECIFIED DIMENSIONAL TOLERANCES FRACTIONAL: ±1/16 X.XX: ±.03 X.XXX: ±.015 ANGULAR: ±1° DEBURR ALL SHARP EDGES. ALL MACHINED SURFACES TO HAVE A 125 RMS FINISH UNLESS NOTED OTHERWISE. | DRAWN BY: ACC |
| THIRD ANGLE PROJECTION | CHECKED BY: AVD |
| | PROTOTYPE BY: ACC |
| | PROTOTYPE DATE: 11/28/2001 |
| | APPROVED FOR PRODUCTION BY: AVD |
| | PRODUCTION DATE: 11/28/2001 |

| | | | |
|--|---------|----------|--------|
| SALCO PRODUCTS, INC. | | | |
| PART NAME: HOPPER AERATOR ASSEMBLY RIGHT | | | |
| MATERIAL: SEE BOM | | | |
| PROJECT #: | 010910 | SHEET #: | 1 OF 1 |
| DRAWING #: | E16456 | SCALE: | 1:1 |
| PART #: | PD1AHRA | | |